

Thematic review series: Adipocyte Biology

## Lipodystrophies: windows on adipose biology and metabolism

Robert A. Hegele,<sup>1</sup> Tisha R. Joy, Salam A. Al-Attar, and Brian K. Rutt

Robarts Research Institute and Schulich School of Medicine and Dentistry, University of Western Ontario, London, Ontario, Canada N6A 5K8

**Abstract** The lipodystrophies are characterized by loss of adipose tissue in some anatomical sites, frequently with fat accumulation in nonatrophic depots and ectopic sites such as liver and muscle. Molecularly characterized forms include Dunnigan-type familial partial lipodystrophy (FPLD), partial lipodystrophy with mandibuloacral dysplasia (MAD), Berardinelli-Seip congenital generalized lipodystrophy (CGL), and some cases with Barraquer-Simons acquired partial lipodystrophy (APL). The associated mutant gene products include 1) nuclear lamin A in FPLD type 2 and MAD type A; 2) nuclear lamin B2 in APL; 3) nuclear hormone receptor peroxisome proliferator-activated receptor  $\gamma$  in FPLD type 3; 4) lipid biosynthetic enzyme 1-acylglycerol-3-phosphate *O*-acyltransferase 2 in CGL type 1; 5) integral endoplasmic reticulum membrane protein seipin in CGL type 2; and 6) metalloproteinase ZMPSTE24 in MAD type B. An unresolved question is whether metabolic disturbances are secondary to adipose repartitioning or result from a direct effect of the mutant gene product. Careful analysis of clinical, biochemical, and imaging phenotypes, using an approach called “phenomics,” reveals differences between genetically stratified subtypes that can be used to guide basic experiments and to improve our understanding of common clinical entities, such as metabolic syndrome or the partial lipodystrophy syndrome associated with human immunodeficiency virus infection.—Hegele, R. A., T. R. Joy, S. A. Al-Attar, and B. K. Rutt. **Lipodystrophies: windows on adipose biology and metabolism.** *J. Lipid Res.* 2007. 48: 1433–1444.

**Supplementary key words** fatty acid • metabolism • obesity • type 2 diabetes • insulin resistance • dyslipidemia • genetics • medical imaging • laminopathy • nuclear hormone receptors

Lipodystrophies are an interesting group of clinical disorders that are most often characterized by lipoatrophy or selective loss of adipose tissue from particular anatomical regions, ranging from localized to generalized (1). The extent of adipose loss usually determines the severity of the associated clinical and metabolic manifestations (2).

Expansion of spared adipose stores in partial lipodystrophies is one likely mechanism that leads to clinical and metabolic manifestations (3). Patients with lipodystrophy often have some of the disturbances that define the common metabolic syndrome, such as increased visceral fat, dyslipidemia (increased triglycerides and decreased HDL), hypertension, dysglycemia, insulin resistance, and sometimes increased predisposition to atherosclerosis (3).

Lipodystrophies can broadly be classified into “familial” or “genetic” and “acquired” types (1–4). The molecular basis of disease has been characterized in two subtypes of congenital generalized lipodystrophy (CGL), in two subtypes of familial partial lipodystrophy (FPLD), and in some patients with acquired partial lipodystrophy (APL). Lipodystrophy can also be a component of certain rare inherited multisystem syndromes (1). It can also appear to be acquired without an obvious germline basis, such as in some patients with acquired generalized lipodystrophy (AGL) and in the partial lipodystrophy syndrome that is associated with infection and treatment of human immunodeficiency virus (HIVPL) (1). Localized lipodystrophies characterized by loss of subcutaneous fat from small regions of a limb can be drug-induced, pressure-induced, panniculitis-induced, or idiopathic (1, 2). Although insulin resistance in lipodystrophies could be secondary to adipose redistribution and/or central obesity, the altered products of the mutated causative genes might also act directly in pathogenesis and might illuminate new causative mechanisms for common insulin resistance (3, 4).

Before the molecular genetic era, the classification of lipodystrophies was based on clinical features, mainly the pattern and extent of adipose tissue loss and the evidence for heritability. Defining the molecular genetic basis of certain lipodystrophies has since shown heterogeneity with respect to both causative genes and the range of mutations within causative genes. This review will begin with general (“pre-molecular”) clinical descriptions of various lipo-

Manuscript received 5 March 2007.

Published, *JLR Papers in Press*, March 20, 2007.  
DOI 10.1194/jlr.R700004-JLR200

<sup>1</sup>To whom correspondence should be addressed.  
e-mail: hegele@robarts.ca

Copyright © 2007 by the American Society for Biochemistry and Molecular Biology, Inc.

This article is available online at <http://www.jlr.org>

dystrophies, followed by summations of current molecular genetic understanding and then brief discussions of how postgenomic molecular stratification and careful evaluation using “phenomics” (4), including magnetic resonance imaging, have revealed subtle differences (Table 1) that can suggest hypotheses for future cellular and molecular studies. Finally, other important aspects and forms of lipodystrophy, including HIVPL, will be discussed in the context of the molecular genetics of inherited lipodystrophies.

## CGL (BERARDINELLI-SEIP SYNDROME)

### Clinical features of CGL

CGL was first described more than a half-century ago by Berardinelli (5) and later by Seip (6). CGL is inherited in an autosomal recessive manner and is clinically characterized by a generalized absence or near-absence of adipose tissue. Affected individuals are usually recognized soon after birth because of almost complete lack of fat and prominent musculature. The childhood years are distinguished by a voracious appetite, accelerated linear growth, advanced bone age, and marked acanthosis nigricans (7, 8). Acromegaloid features, including enlargement of hands, feet, and jaw, are often present. Associated features include umbilical hernia, hepatomegaly secondary to hepatic steatosis that can progress to cirrhosis, splenomegaly, lymphadenopathy, and focal lytic lesions of the appendicular bones (7–9). Cardiomyopathy and mental retardation may variably occur (10, 11). Metabolic complications include fasting hyperglycemia, diabetes (often with marked insulin resistance), hypertriglyceridemia (sometimes resulting in pancreatitis), depressed HDL cholesterol, and markedly depressed plasma adiponectin and leptin (12). Affected women can have hirsutism, polycystic ovarian syndrome (PCOS), and menstrual irregularities, whereas among men, reproductive function appears to be unaffected (13).

### Molecular genetics of CGL

CGL was first mapped genetically to chromosome 9q34 (14); this locus is now designated CGL1 [Mendelian Inheritance in Man (MIM) 608594] (14). CGL1 is caused by mutations in the *AGPAT2* gene, which encodes 1-acylglycerol-3-phosphate *O*-acyltransferase 2, also called lysophosphatidic acid acyltransferase- $\beta$  (15) or 1-acyl-*sn*-glycerol-3-phosphate acetyltransferase (EC 2.3.1.51). *AGPAT2* is important in the metabolism of lysophosphatidic acid and was correlated with enhanced transcription and synthesis of interleukin-6 and tumor necrosis factor- $\alpha$ , consistent with a link between adipocyte biology and cytokine expression (16). Of the genes discovered to date to be causative for the various lipodystrophy syndromes, *AGPAT2* seems to be the most reasonable because of its biochemical activity, although the precise pathogenic mechanism causing a specific impact on adipose tissue remains undefined. *AGPAT2* mutations in CGL1 are shown in Fig. 1. Most *AGPAT2* mutations in CGL1 are of the nonsense or aberrant splicing variety. Most would result in complete defi-

cient enzyme function in the homozygous state. There is no obvious correlation of mutation severity with phenotype severity. Murine studies have shown a lipodystrophy phenotype in mice in which the closely related *Agpat6* gene encoding the related enzyme AGPAT6 has been deleted (17), but screening of human lipodystrophy patients has shown no potentially disease-causing mutations in *Agpat6* (R. A. Hegele, unpublished observations).

Homozygosity mapping in CGL families from Lebanon and Norway identified a second locus on chromosome 11q13 (18), now designated CGL2 (MIM 269700). Using microsatellite markers, the minimal region for this locus was narrowed to a single causative gene that had 87% identity to the mouse “ $\gamma$ -3-linked gene” (*Gng3lg*) product and partial homology to the *Drosophila* CG9904 protein (18). The open reading frame of this gene, also called *BSCL2* (MIM 606158), encodes a deduced 398 amino acid integral membrane protein localized to the endoplasmic reticulum of eukaryotic cells, dubbed “seipin” (18, 19). This protein is expressed mainly in brain and testes; it has at least two hydrophobic amino acid stretches, but as yet its function, and thus the mechanism(s) by which altered function might lead to CGL2, is largely unknown (19). To date, >12 mutations in the *BSCL2* gene have been identified (Fig. 2). Most *BSCL2* mutations in CGL2 are of the nonsense or aberrant splicing variety. Most would result in complete deficient protein function in the homozygous state. There is no obvious correlation between mutation severity and phenotype severity. Interestingly, an unrelated neurological disorder, distal spinal muscular atrophy type 5 (Silver syndrome; MIM 600794), was found to be caused by heterozygous mutations in *BSCL2* (20). Screening studies indicate that ~50% of individuals with a clinical diagnosis of CGL have no sequence mutation in either *AGPAT2* or *BSCL2*, suggesting the existence of other loci (R. A. Hegele, unpublished observations).

### CGL1 and CGL2 phenotypes considered in the light of molecular diagnosis

The literature contains fairly detailed clinical reports of >200 CGL patients, with approximately equal numbers of CGL1 and CGL2 subjects. These relatively large numbers have allowed for comparisons of specific attributes between the two molecular types (Table 1). For instance, it appears that hepatic dysfunction, hyperlipidemia, diabetes mellitus, and hypertrophic cardiomyopathy were each significant contributors to morbidity in subjects with both CGL1 and CGL2, with no clear differences in their prevalence (21). However, CGL2 appeared to have a higher incidence of premature death than CGL1 and a pattern of lipodystrophy that was distinguished by earlier onset and greater severity (21). Also, subjects with CGL2 had a significantly higher prevalence of intellectual impairment than those with CGL1 or CGL with no detected molecular basis (21, 22). In addition, cystic angiomas with progressive incapacitating bone involvement was associated with mutations in *AGPAT2* but not seipin (22), clarifying that a syndrome composed of CGL with systemic cystic angiomas, sometimes called Brunzell syndrome (23), was actually a subtype of CGL1. Cardiomyopathy

TABLE 1. Clinical features

Variable	Congenital Generalized Lipodystrophy	Familial Partial Lipodystrophy	Acquired Generalized Lipodystrophy	Acquired Partial Lipodystrophy	HIV-Related Lipodystrophy
	CGL1 (AGPAT2)	CGL2 (BSCL2)	FPLD2 (LMNA) Diabetic	FPLD3 (PPARG) Nondiabetic	
Demographics					
Age at onset	Soon after birth	Soon after birth	Puberty	Puberty to adulthood	Typically <20 years
Adipose distribution	Normal to underweight	Normal to underweight	Normal	Normal to overweight	Normal
Body mass index (based on World Health Organization criteria)	+++	+++	0	0 to ++	0 to +++
Mechanical fat loss (retro-orbital/palm/sole)	0	++++	0	0	Variable loss of palm fat; no loss of retro-orbital fat
Limb fat loss	++++	++++	++++	++++ (distal predominantly)	++ to +, but normal or increased in lower extremities
Trunk fat	↓↓↓	↓↓↓	↑↑↑	↑↑↑	↓ to ↓↓
Gluteal fat	↓↓↓	↓↓↓	↓↓↓	↓↓↓	0 to ↑↑
Bone marrow fat	↓↓↓	↓↓↓	↓↓↓	↓↓↓	0
Hepatic steatosis	+++	+++	0 to ++	+++	Rare
Clinical features	Very common	Very common	Present	Typically present	Common
Diabetes	Adolescence	<10 years	~35-45 years	Adolescence to adulthood	Adulthood
Age at onset of diabetes	Rare	Rare	Present	Present	Can be present (<45 years)
Hypertension	Present	Present	Present	Present	Can be present
Acanthosis nigricans	Can be present	External genitalia pseudohypertrophy often present	External genital pseudohypertrophy can be present; PCOS rare	PCOS rate	Rare
Hirsutism	No changes			Menstrual anomalies or PCOS often present	Rare
Sexual development/function	Unknown	Unknown	~50%	Typically rare	Androgen deficiency common in men; PCOS rare
Early coronary artery disease	Unknown	Unknown	~50%	Possible	Possible
Metabolic parameters	++++	+++	++	+++	++ to ++++
Increased fasting insulin	++++	+++	++	+++	++ to ++++
Increased triglyceride	++++	+++	+++	+++	++ to ++++
Decreased HDL	0 to ++ <sup>a</sup>	0 to ++ <sup>a</sup>	0 to +	0 to +	++ to ++++
Increased free fatty acids	Unknown	Unknown	0 to +	Unknown	+++ to ++++
Leptin	↓↓↓	↓↓↓ <sup>a</sup>	↑↑↑	↑↑↑	0 to ↑↑
Adiponectin	↑↑↑ <sup>a</sup>	↑↑↑	↑↑↑	↑↑↑	↓↓↓
Increased C-reactive protein	Unknown	Unknown	+	Unknown	0 to ++
Other features	Not associated with mental retardation; cardiomyopathy can be present; bone cysts can be present	Mental retardation possible; higher risk of cardiomyopathy than CGL1; bone cysts may be present	+	Subgroups: associated with autoimmune conditions; associated with panniculitis; idiopathic	Associated with low complement factor C3, autoimmune disorders, membranoproliferative glomerulonephritis

0, absent; ↑ to ↑↑↑, present or increased to varying degrees as indicated; ↓ to ↓↓↓, depressed to varying degrees as indicated; CGL, congenital generalized lipodystrophy; FPLD, familial partial lipodystrophy; PCOS, polycystic ovarian syndrome.<sup>a</sup> Summary characteristics are not further subdivided according to mutation type.

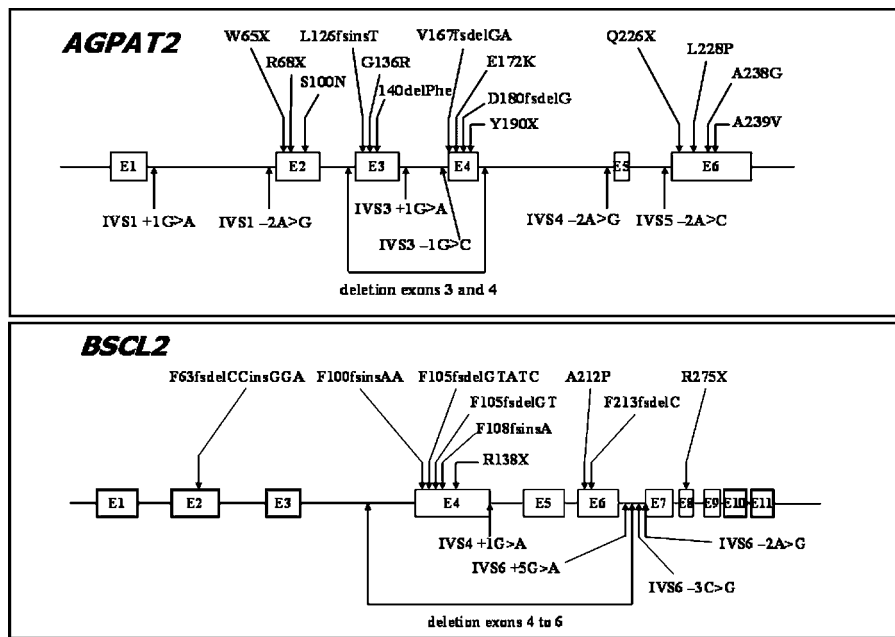

Fig. 1. Genomic maps of *AGPAT2* (top panel) and *BSCL2* (bottom panel) showing reported mutations in patients with congenital generalized lipodystrophy (CGL1 and CGL2, respectively). Exons are shown as numbered boxes. IVS, intron.

appears to be more severe in CGL2 (11). A multinational study showed lower serum leptin and earlier diabetes onset in CGL2 compared with CGL1 (10), whereas a study in Brazilian patients showed lower serum leptin in CGL1 compared with CGL2 but earlier diabetes onset

and higher serum insulin in CGL2 compared with CGL1 (24). Finally, both CGL1 and CGL2 subtypes demonstrate a lack of metabolically active adipose tissue within most subcutaneous, intermuscular, bone marrow, intra-abdominal, and intrathoracic sites (25). However, mechanical adipose

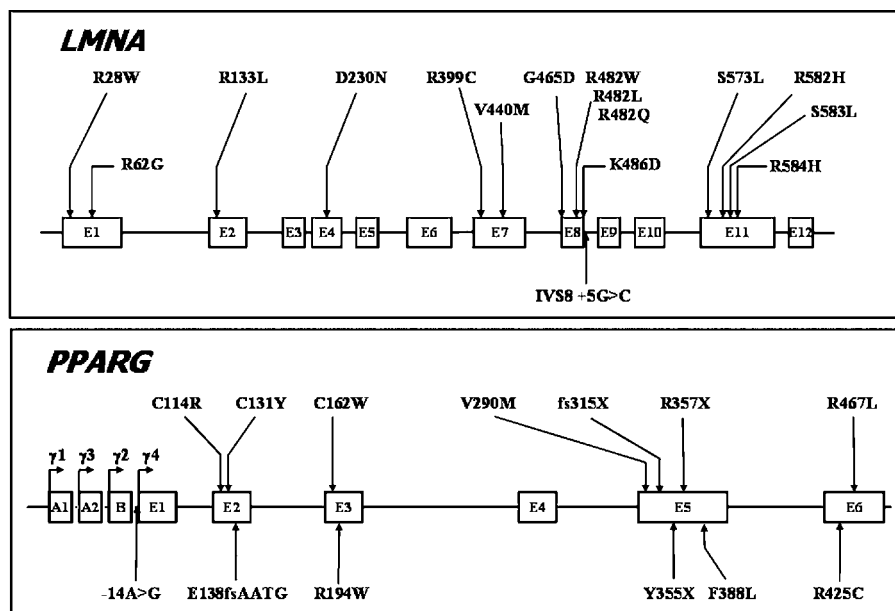

Fig. 2. Genomic maps of *LMNA* (top panel) and *PPARG* (bottom panel) showing reported mutations in patients with familial partial lipodystrophy (FPLD2 and FPLD3, respectively). For *LMNA*, the single FPLD2 splicing mutation is shown below the genomic map. For *PPARG*, FPLD3 mutations that appear to act through a dominant negative mechanism are shown above the genomic map, whereas FPLD3 mutations that act through a dominant negative mechanism are shown below the genomic map. The promoters for the tissue-specific *PPARG* mRNA isoforms are designated  $\gamma 1$ ,  $\gamma 3$ ,  $\gamma 2$ , and  $\gamma 4$ , and their associated untranslated exons are designated A1, A2, B, and E1, respectively. Exons are shown as numbered boxes. IVS, intron.



tissue in palms, soles, orbits, scalp, and periarticular regions was absent in CGL2 but not in CGL1 (25). Together, these findings indicate that CGL2 is a more severe phenotype than CGL1, with more extensive fat loss and biochemical changes, more severe cardiomyopathy and intellectual impairment, earlier diabetes onset, and possibly earlier mortality.

## FPLD (DUNNIGAN OR KOBBERLING SYNDROME)

### Clinical features of FPLD

FPLD, originally described in the 1970s independently by Kobberling et al. (26) and Dunnigan et al. (27), often shows autosomal dominant inheritance. FPLD is generally characterized by progressive and gradual subcutaneous adipose tissue loss from the extremities, classically commencing in puberty (26–28). Thus, during infancy and childhood, affected individuals cannot be easily distinguished clinically from unaffected individuals. Across all FPLD types, the loss of adipose tissue from the extremities is accompanied by variable adipose tissue loss in the trunk and chest. Also, increased fat deposition within muscles and liver can occur (29–32). Metabolic manifestations of FPLD include hypertriglyceridemia, depressed HDL cholesterol, dysglycemia developing into diabetes, acanthosis nigricans, and, among women, hirsutism, PCOS, and menstrual irregularities (33). The risk of developing diabetes is higher among women than among men, particularly for multiparous women with excessive central adipose deposition (34).

### Molecular genetics of FPLD

FPLD is subdivided into three forms: FPLD1 (Kobberling type; MIM 608600), FPLD2 (Dunnigan type; MIM 151660), and FPLD3 (MIM 603637) (31, 35, 36). FPLD1 has an unknown molecular basis. FPLD2 results from heterozygous mutations in the *LMNA* gene encoding nuclear lamin A/C (MIM 150330) (35). The *LMNA* mutations implicated in FPLD2 are shown in Fig. 2. Most *LMNA* mutations in FPLD2 are of the missense variety, with only one splicing mutation identified to date (Fig. 2). Furthermore, screening for larger scale genomic variants in *LMNA*, such as deletions and duplications in patients with lipodystrophy, has revealed no mutations of this type (R. A. Hegele, unpublished observations). The family of diseases that result from >100 nuclear lamin mutations are called “laminopathies,” and in addition to FPLD2, mutations in *LMNA* can cause Hutchinson Gilford progeria syndrome (HGPS), mandibuloacral dysplasia (MAD), Emery-Dreifuss muscular dystrophy, limb-girdle muscular dystrophy, dilated cardiomyopathies, cardiac conduction defects, Charcot-Marie-Tooth disease, atypical Werner syndrome, and various overlapping syndromes (37). Most FPLD2 mutations in *LMNA* are missense mutations within the 3' end of the gene; exons 11 and 12 are specific for the lamin A isoform, so that missense mutations in these exons implicate the lamin A isoform in FPLD2 (37). Most

*LMNA* mutations in FPLD2 are downstream of the nuclear localization sequence (NLS), which divides lamin A into the structural rod domain on the N-terminal side and the DNA binding domain on the C-terminal side. This had led some to conjecture that the molecular disease mechanism in FPLD2, and indeed in the other laminopathies that are caused by mutations within or near the lamin DNA binding domain, is related to altered interactions of transcription factors or other DNA binding molecules, in contrast to a disease resulting from altered nuclear envelope structure and integrity from mutations that occur upstream of the NLS within the lamin A/C rod domain (37).

The mechanisms by which a mutation in *LMNA* leads specifically to a dystrophy of adipose cells are incompletely defined. It is not clear which of the multiple normal roles of the nuclear lamina, such as the maintenance of nuclear shape and structure but also nonstructural roles such as transcriptional regulation, nuclear pore positioning and function, and the organization of heterochromatin (38), become disrupted by FPLD2 mutations in *LMNA*. It is not even clear whether the same mechanism is responsible for the pathogenesis of each laminopathy. One interesting development has been the demonstration that progeria mutations in *LMNA* affect the farnesylation of prelamin A, which behaves as an intracellular toxin (39). Indications are that treatment with oral farnesyl transferase inhibitors alters the natural progression of disease (40). If a similar pathogenic mechanism can be shown for the FPLD2 mutations in *LMNA*, this would suggest a new approach to treatment for this disease.

Two recently described FPLD2 mutations, *LMNA* D230N and R399C, occur upstream of the lamin A NLS (41), suggesting that the position of the mutation within the secondary and/or tertiary structure of lamin A might also be a key determinant of pathogenicity (37). Reannotation of sequences of previously studied genes can identify new sequences to be screened, leading to the discovery of new mutations (42). In this regard, a recent version of the National Center for Biotechnology Information AceView, which annotates genes by aligning cDNA and expressed sequence tags, indicates that *LMNA* is more variable at the transcriptional level than was thought previously, with perhaps >40 exons and >10 distinct mRNA transcripts (<http://www.ncbi.nlm.nih.gov/IEB/Research/Acembly>). The evolving *LMNA* sequence annotation might identify new regions that harbor mutations, helping to explain the range of laminopathy phenotypes, including FPLD2.

FPLD3 (MIM 604367) results from any of more than a dozen heterozygous mutations in the *PPARG* gene encoding peroxisome proliferator-activated receptor  $\gamma$  (PPAR $\gamma$ ; MIM 601487) (43–51). The *PPARG* mutations implicated in FPLD3 are shown in Fig. 2. Both “dominant negative” and “haploinsufficiency” mechanisms have been proposed to explain the pathogenicity of the *PPARG* mutations. According to the dominant negative hypothesis, the mutant allele disrupts wild-type function by direct interference. In the case of PPAR $\gamma$ , the mutant receptor would compete with the wild type for DNA binding. In contrast, with haplo-

insufficiency, 50% reduced gene expression results from one nonfunctional allele, compared with the greater reductions in gene expression and function resulting from dominant negative mutations. Careful cellular assays indicate that seven PPAR $\gamma$  mutations (C114R, C131Y, C162W, FS315X, R357X, P467L, and V290M) act via a dominant negative mechanism (44, 51), whereas six PPAR $\gamma$  mutations ( $-14A>G$ , F388L, E138fs $\Delta$ AATG, Y355X, R194W, and R425C) act through haploinsufficiency (45–50) (Fig. 2).

Because of the extremely well-studied role of PPAR $\gamma$  in adipocyte biology, the mechanistic link to FPLD3 is not as obtuse as for some of the other lipodystrophy genes. For the dominant negative *PPARG* mutations, it has been reported that receptor mutants lacked DNA binding and transcriptional activity but could translocate to the nucleus to interact with PPAR $\gamma$  coactivators and inhibit co-expressed wild-type receptor, with resultant attenuation of the expression of PPAR $\gamma$  target genes (44). This suggested that the mutants restricted wild-type PPAR $\gamma$  action via a non-DNA binding, transcriptional interference mechanism involving the sequestration of functionally limiting coactivators (44). Another proposed mechanism was reduced promoter turnover rate for certain dominant negative mutant PPAR $\gamma$  receptors, with the result that the mutant would eventually outcompete the wild-type receptor for promoter binding sites (49). In any event, the mechanisms through which mutant PPAR $\gamma$  receptors lead ultimately to the expression of a lipodystrophy phenotype are complex and likely varied.

Genomic sequence analysis, screening known coding regions, revealed that approximately 50% of FPLD patients have no mutation on either *LMNA* or *PPARG* genes. The reasons for this may include 1) the presence of mutation types not detected by DNA sequence analysis, such as copy number variations; 2) genetic heterogeneity with new causative genes yet to be identified; and 3) the presence of mutations in unrecognized functionally important sequences of *LMNA* or *PPARG*.

#### **FPLD2 and FPLD3 phenotypes considered in the light of molecular diagnosis**

There appears to be little difference in the severity of clinical presentation between the various *LMNA* missense mutations that lead to FPLD2. However, a single *LMNA* splicing mutation has been found in two sisters with a very severe FPLD2 phenotype (52). Other splicing mutations in *LMNA* also lead to severe phenotypes, such as the splicing mutation in exon 11 that underlies most cases of HGPS. It is perhaps noteworthy that HGPS patients have lipodystrophy as part of their cluster of systemic abnormalities (37). Also, the severity of the phenotype in FPLD2 can be modulated by the presence of other mutations: in one striking example, a patient with a severe form of FPLD2 with acromegaly and aggressive vascular disease was a compound heterozygote for the R482Q mutation and the V440M mutation, which on its own is not pathogenic (53).

Among individual *PPARG* mutations, there appears to be little correlation of mutation type with phenotype severity. The severity of adipose tissue loss and metabolic distur-

bances appears to be similar among individuals with dominant negative and haploinsufficiency mutations. All FPLD3 patients with *PPARG* haploinsufficiency mutations were ascertained based upon a clinical diagnosis of lipodystrophy (45–50). Thus, virtually every patient with a *PPARG* mutation has had partial lipodystrophy as a core phenotype.

Table 1 summarizes clinical features compiled from female subjects with FPLD2 and FPLD3. Subjects with FPLD2 were further subdivided according to the presence or absence of diabetes. At the clinical and biochemical levels, it appears that FPLD3, compared with FPLD2, is associated with 1) less extensive adipose loss clinically; 2) more severe and/or earlier clinical end points, such as acanthosis nigricans, hepatic steatosis, PCOS, and hirsutism; 3) more severe hypertension; 4) earlier onset of type 2 diabetes; 5) greater biochemical insulin resistance; 6) pronounced depression of adipocytokines; and 7) variable biochemical responses to thiazolidinedione treatment. One clear difference is the documentation of early heart disease among women with FPLD2 (54). The early atherosclerosis that was clearly seen in women with FPLD2 was less definitively shown in the smaller number of FPLD3 subjects accumulated to date. In aggregate, it appears that the clinical and biochemical derangements in FPLD3 subjects are out of proportion to the extent of lipodystrophy compared with FPLD2 subjects, suggesting that the *PPARG* mutations might have additional and independent effects on metabolism.

#### **APL (BARRAQUER-SIMONS SYNDROME)**

APL (MIM 608709) was initially reported >100 years ago (55–57). A family history is usually absent in APL, whereas a wide range of secondary factors and conditions is often associated (58). For instance, autoimmune disorders such as systemic lupus erythematosus, dermatomyositis, hypocomplementemia, and membranoproliferative glomerulonephritis are sometimes seen in association with APL (58). The sporadic expression and frequent requirement for secondary factors indicate that APL is a complex trait, perhaps with a component of genetic susceptibility. Like some of the lipodystrophies described above, there is a female preponderance of ascertained cases at a ratio of  $\sim$ 4:1. Affected individuals develop adipose tissue loss affecting primarily the face, neck, arms, thorax, and upper abdomen in progressive cephalocaudal order, commencing in childhood or adolescence. The adipose stores of the gluteal regions and lower extremities (including soles) tend to be either preserved or increased, particularly among women. Variable fat loss of the palms, but no loss of intramarrow or retro-orbital fat, has been demonstrated. Patients with membranoproliferative glomerulonephritis develop lipodystrophy at an earlier age compared with those without renal disease. Although the prevalence of diabetes has been shown to be only  $\sim$ 10%, diabetic APL patients were predominantly female (58). The clinical attributes of APL are shown in Table 1.

To resolve whether APL had a component of genetic susceptibility (58), we used candidate gene sequencing to identify genomic DNA sequence mutations that were present in APL patients but absent in healthy individuals. In 2001, we used genomic information available at that time to screen candidate genes encoding nuclear envelope proteins, including *LBR*, *LMNB1*, and *LMNB2*, which encode lamin B receptor, lamin B1, and lamin B2, respectively (59). We then sequenced these candidate genes in patients with APL who had no mutations in *LMNA* (59). We identified several common polymorphisms but found no disease-causing mutations. We concluded that sequence variants affecting the nuclear lamina proteome were not likely to be associated with APL (59). However, recent observations suggest that early versions of mammalian genome maps underestimated the total numbers of exons. New computational algorithms have revealed thousands of previously unappreciated exons in mammalian genomes (60). Upon revisiting the reannotated genomic structures of nuclear proteome genes, we found that *LMNB2* had only 6 exons identified in 2001 but 12 exons today. We thus developed reagents to interrogate the coding regions of the reannotated *LMNB2* gene (MIM 150341) in nine unrelated APL patients. In four of these patients, we found three new rare *LMNB2* mutations: intron 1 –6G>T, exon 5 p.R215Q (in two patients), and exon 8 p.A407T. Compared with a multiethnic control sample of 1,100 subjects, the relative risk of APL for carriers of these mutations was 110 (95% confidence interval, 36–271;  $P < 0.00001$ ). These novel heterozygous mutations were the first reported in *LMNB2* and the first reported among patients with APL (42). There was no obvious genotype-phenotype correlation. However, the findings indicated how sequencing of a reannotated candidate gene can reveal new disease-associated mutations (42).

### AGL

Like APL, AGL does not follow classical Mendelian patterns of inheritance, but unlike APL, no genetic susceptibility component has been identified for AGL (61). Clinical features of AGL are summarized in Table 1. AGL is typically recognized in childhood and adolescence, with progressive loss of adipose tissue affecting the face and extremities with varying changes in intra-abdominal fat, sparing of retro-orbital and intramarrow adipose stores, and variable loss of adipose tissue in the palms or soles (61). Females tend to be more often affected, or at least ascertained clinically, than males, with a ratio of 3:1. During childhood, affected individuals have a voracious appetite, acanthosis nigricans, and hepatic steatosis. Metabolic changes include low plasma leptin and adiponectin, hyperinsulinemia, diabetes, hypertriglyceridemia, and low plasma HDL. Females with AGL have compromised reproduction, with menstrual irregularities and PCOS. AGL has been subclassified into three groups based largely on clinical attributes: AGL associated with autoimmune disorders, AGL associated with panniculitis, and

idiopathic AGL. Misra and Garg (61) found the prevalence of diabetes and hypertriglyceridemia to be highest in both the autoimmune and idiopathic groups compared with the panniculitis group: ~88% versus 44% for diabetes and ~90% versus 59% for hypertriglyceridemia. To resolve whether AGL had an underlying component of genetic susceptibility, we extensively used candidate gene sequencing of known lipodystrophy genes (*AGPAT2*, *BSCL2*, *LMNA*, *PPARG*, and *LMNB2*) and also candidate genes encoding nuclear envelope proteins, but to date we have found no putative causative or associated mutations (R. A. Hegele, unpublished observations).

### HIVPL

HIV-related lipodystrophy is the most commonly ascertained form of lipodystrophy in the clinic (62). HIVPL affects males and females equally and has been related to the intensity and tonicity of antiretroviral therapy. Adipose redistribution among HIV-infected individuals is very common, affecting up to 50% of individuals, although there is no standard definition or clinical criteria for this diagnosis (62). Initially, patients with HIV-related lipodystrophy were mistakenly presumed to have Cushing syndrome, but careful evaluation revealed unaltered steroid hormone metabolism (63–65). Later reports linked the presence of peripheral lipoatrophy affecting the face and extremities with central lipohypertrophy affecting the dorsocervical and truncal regions. Prospective trials have shown that although peripheral lipoatrophy is common among HIV-infected individuals, truncal adipose distribution can range from lipoatrophy to lipohypertrophy, suggesting that peripheral lipoatrophy is not always linked with central lipohypertrophy (66–68). Other metabolic manifestations of HIV-related lipodystrophy include hypertriglyceridemia, low plasma HDL, insulin resistance, impaired glucose tolerance or diabetes, androgen deficiency, and hepatic steatosis (69–71). PCOS is not found among HIV-infected women, and acanthosis nigricans is also rarely seen, despite the presence of significant insulin resistance (72). In contrast to other forms of lipodystrophy, plasma leptin tends to be normal or even increased, together with low adiponectin (73, 74).

### OTHER SYNDROMES WITH A LIPODYSTROPHY COMPONENT

#### MAD

MAD (MIM 248370) is an extremely rare autosomal recessive disorder characterized by multiple musculoskeletal abnormalities, progeroid features, and lipodystrophy with insulin resistance, hypertriglyceridemia, depressed plasma HDL, and impaired glucose tolerance (1, 75, 76). There are two molecular forms of MAD: type A (MADA; MIM 248370), caused by homozygous missense mutations in *LMNA* (77); and type B (MADB; MIM 608612), caused by compound heterozygous mutations in *ZMPSTE24*



(MIM 606480), which encodes a zinc metalloproteinase involved in proteolytic processing of prelamin A. Defective prelamin A maturation with mutant *ZMPSTE24* leads to the generation of abnormalities in nuclear architecture that underlie the various phenotypes (78). MADA patients had loss of subcutaneous adipose tissue from the extremities, with sparing of the neck and trunk, whereas the MADB patient had global subcutaneous adipose loss involving the face, trunk, and extremities (76).

### SHORT syndrome

SHORT syndrome (MIM 269880) is an extremely rare disorder characterized by short stature, hyperextensible joints and/or inguinal hernia, ocular depression, Rieger anomaly (defective development of cornea and iris), and teething delay. There is no sex predominance, obvious inheritance pattern, or molecular genetic basis. Most af-

ected individuals have depleted adipose stores in the face, upper extremities, and trunk with less effect on the lower extremities. Others have adipose tissue loss of the trunk, gluteal region, and elbows (79–81).

### Progeria syndromes

Features of HGPS (MIM 176670), attributable to mutant *LMNA*, include growth delay, short stature, alopecia, osteolysis, elderly facial features, and lipodystrophy beginning in the first year of life involving the extremities, trunk, and face but sparing intra-abdominal adipose stores. Atherosclerosis is common and represents the major cause of death (82, 83).

Features of Werner syndrome (MIM 277700), attributable to homozygous mutations in *RECQL2* (MIM 604611) encoding a DNA helicase (84), include short stature, late-onset progeroid features, decreased subcutaneous adipose

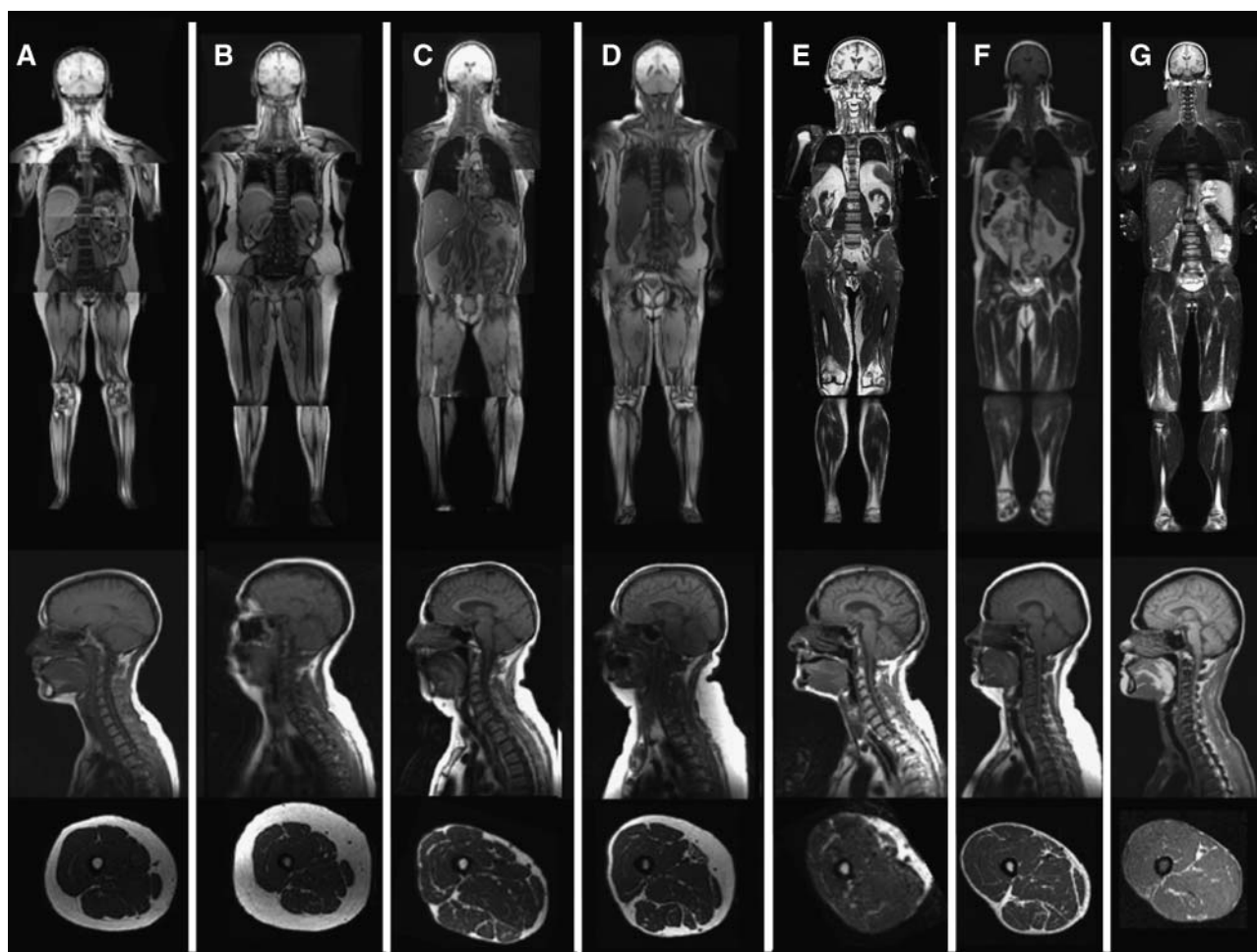
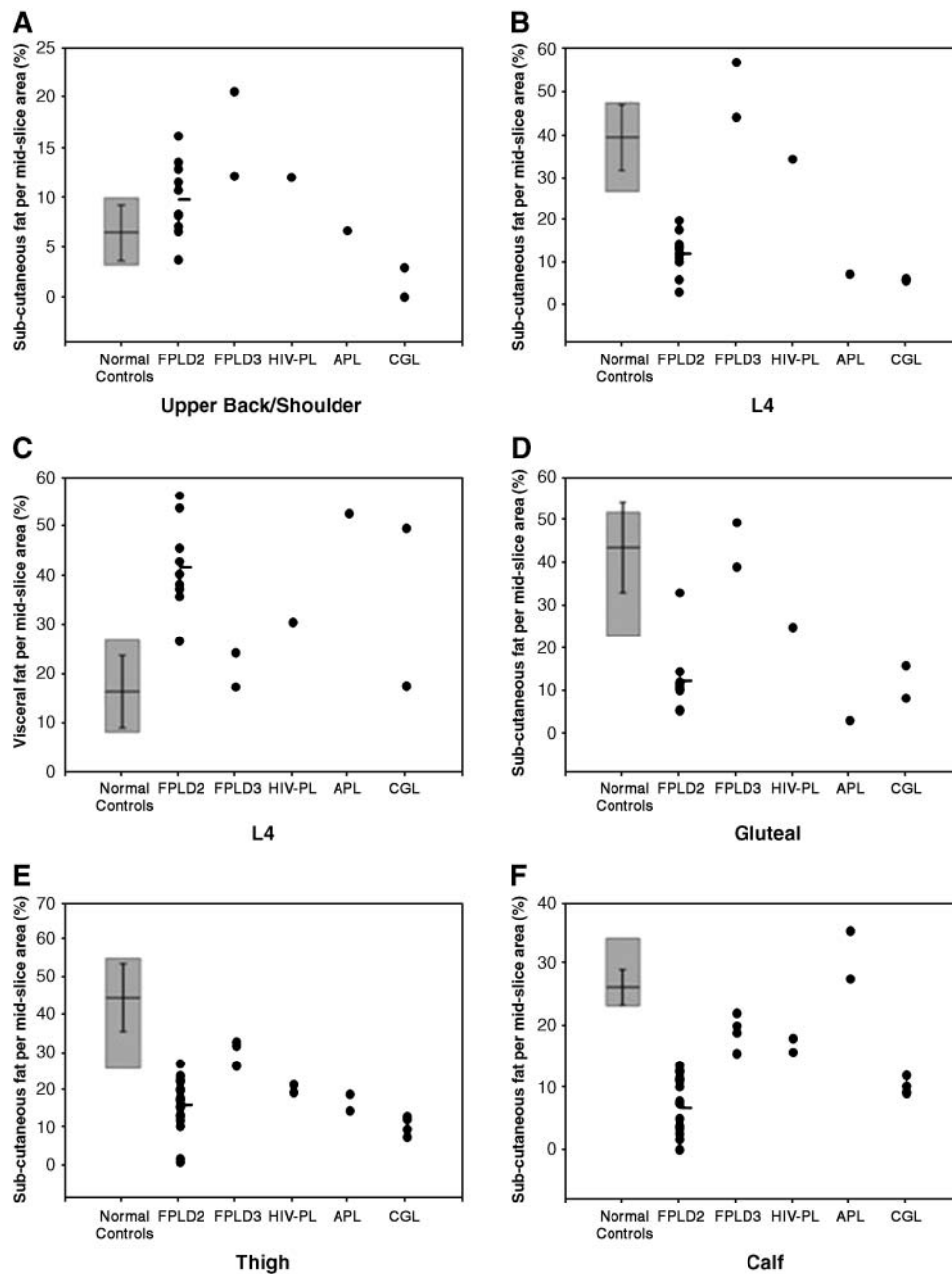

**Fig. 3.** Phenomic evaluation of adipose tissue deposition in females with various lipodystrophies using MRI analysis. A: Control 28 year old female, body mass index (BMI) = 22.4 kg/m<sup>2</sup>. B: Control 50 year old female, BMI = 34.8 kg/m<sup>2</sup>. C: FPLD2 (attributable to *LMNA* R482Q heterozygosity) 63 year old female, BMI = 24.8 kg/m<sup>2</sup>. D: FPLD3 (attributable to *PPARG* F388L heterozygosity) 49 year old female, BMI = 33.4 kg/m<sup>2</sup>. E: Acquired partial lipodystrophy (APL; attributable to *LMNB2* R215Q heterozygosity) 65 year old female, BMI = 20.3 kg/m<sup>2</sup>. F: Human immunodeficiency virus-associated partial lipodystrophy (HIVPL; no mutation) 40 year old female, BMI = 28.3 kg/m<sup>2</sup>. G: CGL (attributable to *BSC12* frameshift mutation fs108insA homozygosity) 41 year old female, BMI = 22.9 kg/m<sup>2</sup>. The top row of images shows composite whole body MRI scans of patients in coronal section. The middle row shows sagittal sections of the head and neck to visualize the dorsocervical fat pad. The bottom row shows cross-sections through the right mid thigh. Quantification of the regional scans of adipose tissues was used to produce the values shown in Fig. 4.



in the trunk, face, and extremities with insulin resistance and diabetes, osteoporosis, cataracts, hypogonadism, numerous skin problems, calcified blood vessels, and early death from cardiovascular disease or cancer (85, 86).

Wiedemann-Rautenstrauch neonatal progeroid syndrome (MIM 264090), or neonatal progeroid syndrome, follows autosomal recessive inheritance. Affected individuals have progeroid features at birth, skull deformities,



**Fig. 4.** Percentage subcutaneous and visceral adipose tissue values in different body segments of lipodystrophy patients and healthy female controls from imaging studies shown qualitatively in Fig. 3. The shaded regions represent the range of adipose tissue values of the normal control group (10 females). Horizontal lines and error bars represent the mean  $\pm$  SD of adipose tissue percentages seen in normal controls. The horizontal lines in FPLD2 plots represent mean values of adipose tissue in these subjects. A: Percentage subcutaneous adipose tissue in the upper back and shoulders. B: Percentage subcutaneous adipose tissue in the abdomen at the level of the fourth lumbar vertebra (L4). C: Percentage visceral adipose tissue in the abdomen-L4 region. D: Percentage subcutaneous adipose tissue in the gluteal region. E: Percentage subcutaneous adipose tissue in the thighs. Values for left and right thighs are plotted as two separate points for each subject. F: Percentage subcutaneous adipose tissue in the calves. Values for left and right calves are plotted as two separate points for each subject. This figure was originally published in BioMed Central (89).

and generalized lipodystrophy fat loss (87). The molecular basis is unknown, but these patients have no mutations in known lipodystrophy genes or in candidate genes encoding nuclear envelope proteins (R. A. Hegele, unpublished observations).

### Phenomic studies of fat distribution using magnetic resonance imaging

We have developed a standardized methodology for semiautomated quantitation of subcutaneous adipose stores from MRI to study differences between subjects with lipodystrophy (88, 89). Inspection of whole body magnetic resonance images, and also regional and segmental scans, showed remarkable differences between different types of lipodystrophy (Fig. 3). After obtaining reference ranges for percentage subcutaneous adipose tissue in normal control subjects for six anatomical sites (Fig. 4), we quantified the percentage adipose in women with FPLD2 (ten subjects), FPLD3 (two subjects), HIVPL (one subject), APL (one subject), and CGL (two subjects).

FPLD2 has long been clinically characterized by decreased adipose deposition in the trunk and increased deposition in the neck and labia. Using MRI, we demonstrated significant differences in FPLD2 patients compared with controls, specifically increased supraclavicular and visceral adipose stores and decreased subcutaneous abdominal, gluteal, thigh, and calf adipose stores (Fig. 4). We also confirmed the subjective clinical impression of differences between FPLD2 and FPLD3 subjects, such as no increase in visceral adipose tissue, no decrease in abdominal subcutaneous adipose tissue, and less dramatic depletion of subcutaneous gluteal, thigh, and calf adipose in FPLD3 compared with FPLD2 patients (Fig. 4). Finally, FPLD3 patients have relatively more truncal adipose tissue and less attenuation of limb adipose tissue than FPLD2 patients; they may also have decreased to absent facial fat (Fig. 4). This supports the clinical impression of less severe adipose tissue alteration but more severe clinical endocrine abnormalities in FPLD3 compared with FPLD2 patients.

We noted that the pattern of adipose repartitioning in the HIVPL subject closely resembled the pattern seen in the FPLD3 subjects (Fig. 4). We documented reduced subcutaneous fat in the upper body, gluteal region, and thigh in both APL and CGL subjects, with increased and decreased calf fat in APL and CGL subjects, respectively (Fig. 4). Finally, we noted consistently reduced fat in the mid thigh across the lipodystrophies (Fig. 4), suggesting that imaging of this bodily region could be a defining clinical biomarker that could help distinguish whether a patient is affected with some form of lipodystrophy when the clinical diagnosis is unclear (Fig. 4). Studies are under way to acquire these quantified traits from a larger number of patients, including males with various lipodystrophy subtypes, both defined molecularly and not. Future application of this quantification method may include the quantification of both thigh and calf depots for “garden variety” obesity, metabolic syndrome, or diabetes. This approach might also be applicable to quantify metabolically important substrata of adipose tissue. Finally, the differ-

ences in adipose tissue distribution between lipodystrophy types might help to identify genetic programs of development or apoptosis related either to affected pathways linked to mutant gene products or to various environmental or pathogenic insults.

### CONCLUSION

Patients with lipodystrophy represent the ultimate in vivo “experiment of nature” with regard to human adipose tissue development, dysfunction, and programmed cell death. For the first century after their initial description, these disorders were classified based on clinical and biochemical features. However, since the first causative mutations in FPLD2 were reported <8 years ago, the power of molecular genetics and biology has rapidly created a new classification framework that enables the examination of these disorders from a genotypic perspective. The associated mutations occur in genes encoding two nuclear envelope structural components (*LMNA* and *LMNB2*), a nuclear hormone receptor (*PPARG*), a metalloproteinase (*ZMPSTE24*), an integral endoplasmic reticulum membrane protein (*BSCL2*), and a lipid biosynthetic enzyme (*AGPAT2*). There are no obvious unifying mechanistic links or pathways that account for this range of gene products. Further molecular heterogeneity is likely to be discovered among patients who currently lack a molecular diagnosis. An unresolved question is whether the metabolic disturbances develop secondarily to adipose tissue repartitioning or result from a direct effect of the individual mutant gene product. Phenomic studies have revealed clinical differences between CGL1 and CGL2 and between FPLD2 and FPLD3, which may soon be translatable into differences in diagnosis, prognosis, and treatment. The example of the lipodystrophies indicates how combining genomic and phenomic perspectives can guide future experiments and perhaps improve our understanding of common clinical entities, such as metabolic syndrome or HIVPL. ■

This work was supported by the Jacob J. Wolfe Distinguished Medical Research Chair, the Edith Schulich Vinet Canada Research Chair (Tier I) in Human Genetics, a Career Investigator Award from the Heart and Stroke Foundation of Ontario, and operating grants from the Canadian Institutes for Health Research, the Heart and Stroke Foundation of Ontario (Grant NA 5320), the Ontario Research Fund, and Genome Canada through the Ontario Genomics Institute. S.A.A. is the recipient of a Master’s studentship award from the Heart and Stroke Foundation of Ontario. Rebecca Pollex provided excellent editorial assistance.

### REFERENCES

1. Garg, A. 2004. Acquired and inherited lipodystrophies. *N. Engl. J. Med.* **350**: 1220–1234.
2. Simha, V., and A. Garg. 2006. Lipodystrophy: lessons in lipid and energy metabolism. *Curr. Opin. Lipidol.* **17**: 162–169.

3. Hegele, R. A. 2003. Monogenic forms of insulin resistance: apertures that expose the common metabolic syndrome. *Trends Endocrinol. Metab.* **14**: 371–377.
4. Hegele, R. A. 2004. Phenomics, lipodystrophy, and the metabolic syndrome. *Trends Cardiovasc. Med.* **14**: 133–137.
5. Berardinelli, W. 1954. An undiagnosed endocrinometabolic syndrome: report of 2 cases. *J. Clin. Endocrinol. Metab.* **14**: 193–204.
6. Seip, M. 1959. Lipodystrophy and gigantism with associated endocrine manifestations. A new diencephalic syndrome? *Acta Paediatr.* **48**: 555–574.
7. Seip, M., and O. Trygstad. 1996. Generalized lipodystrophy, congenital and acquired (lipoatrophy). *Acta Paediatr. Suppl.* **413**: 2–28.
8. Westvik, J. 1996. Radiological features in generalized lipodystrophy. *Acta Paediatr. Suppl.* **413**: 44–51.
9. Fleckenstein, J. L., A. Garg, F. J. Bonte, M. F. Vuitch, and R. M. Peshock. 1992. The skeleton in congenital, generalized lipodystrophy: evaluation using whole-body radiographic surveys, magnetic resonance imaging and technetium-99m bone scintigraphy. *Skeletal Radiol.* **21**: 381–386.
10. Agarwal, A. K., V. Simha, E. A. Oral, S. A. Moran, P. Gorden, S. O'Rahilly, Z. Zaidi, F. Gurakan, S. A. Arslanian, A. Klar, et al. 2003. Phenotypic and genetic heterogeneity in congenital generalized lipodystrophy. *J. Clin. Endocrinol. Metab.* **88**: 4840–4847.
11. Bhayana, S., V. M. Siu, G. I. Joubert, C. L. Clarson, H. Cao, and R. A. Hegele. 2002. Cardiomyopathy in congenital complete lipodystrophy. *Clin. Genet.* **61**: 283–287.
12. Haque, W. A., I. Shimomura, Y. Matsuzawa, and A. Garg. 2002. Serum adiponectin and leptin levels in patients with lipodystrophies. *J. Clin. Endocrinol. Metab.* **87**: 2395–2998.
13. Agarwal, A. K., and A. Garg. 2006. Genetic basis of lipodystrophies and management of metabolic complications. *Annu. Rev. Med.* **57**: 297–311.
14. Garg, A., R. Wilson, R. Barnes, E. Arioglu, Z. Zaidi, F. Gurakan, N. Kocak, S. O'Rahilly, S. I. Taylor, S. B. Patel, et al. 1999. A gene for congenital generalized lipodystrophy maps to human chromosome 9q34. *J. Clin. Endocrinol. Metab.* **84**: 3390–3394.
15. Agarwal, A. K., E. Arioglu, S. De Almeida, N. Akkoc, S. I. Taylor, A. M. Bowcock, R. I. Barnes, and A. Garg. 2002. AGPAT2 is mutated in congenital generalized lipodystrophy linked to chromosome 9q34. *Nat. Genet.* **31**: 21–23.
16. Agarwal, A. K., and A. Garg. 2003. Congenital generalized lipodystrophy: significance of triglyceride biosynthetic pathways. *Trends Endocrinol. Metab.* **14**: 214–221.
17. Vergnes, L., A. P. Beigneux, R. Davis, S. M. Watkins, S. G. Young, and K. Reue. 2006. Agpat6 deficiency causes subdermal lipodystrophy and resistance to obesity. *J. Lipid Res.* **47**: 745–754.
18. Magre, J., M. Delapine, E. Khallouf, T. Gedde-Dahl, Jr., L. Van Maldergem, E. Sobel, J. Papp, M. Meier, A. Megarbane, A. Bachy, et al. 2001. Identification of the gene altered in Berardinelli-Seip congenital lipodystrophy on chromosome 11q13. *Nat. Genet.* **28**: 365–370.
19. Lundin, C., R. Nordstrom, K. Wagner, C. Windpassinger, H. Andersson, G. von Heijne, and I. Nilsson. 2006. Membrane topology of the human seipin protein. *FEBS Lett.* **580**: 2281–2284.
20. Windpassinger, C., M. Auer-Grumbach, J. Irobi, H. Patel, E. Petek, G. Horl, R. Malli, J. A. Reed, I. Dierick, N. Verpoorten, et al. 2004. Heterozygous missense mutations in BSCL2 are associated with distal hereditary motor neuropathy and Silver syndrome. *Nat. Genet.* **36**: 271–276.
21. Van Maldergem, L., J. Magre, T. E. Khallouf, T. Gedde-Dahl, Jr., M. Delapine, O. Trygstad, E. Seemanova, T. Stephenson, C. S. Albott, F. Bonnici, et al. 2002. Genotype-phenotype relationships in Berardinelli-Seip congenital lipodystrophy. *J. Med. Genet.* **39**: 722–733.
22. Fu, M., R. Kazlauskaitė, F. Baracho Mde, M. G. Santos, J. Brandao-Neto, S. Villares, F. S. Celi, B. L. Wajchenberg, and A. R. Shuldiner. 2004. Mutations in Gng3lg and AGPAT2 in Berardinelli-Seip congenital lipodystrophy and Brunzell syndrome: phenotype variability suggests important modifier effects. *J. Clin. Endocrinol. Metab.* **89**: 2916–2922.
23. Brunzell, J. D., S. W. Shankle, and J. E. Bethune. 1968. Congenital generalized lipodystrophy accompanied by cystic angiomas. *Ann. Intern. Med.* **69**: 501–516.
24. Gomes, K. B., V. C. Pardini, A. C. Ferreira, and A. P. Fernandes. 2005. Phenotypic heterogeneity in biochemical parameters correlates with mutations in AGPAT2 or Seipin genes among Berardinelli-Seip congenital lipodystrophy patients. *J. Inher. Metab. Dis.* **28**: 1123–1131.
25. Simha, V., and A. Garg. 2003. Phenotypic heterogeneity in body fat distribution in patients with congenital generalized lipodystrophy caused by mutations in the AGPAT2 or seipin genes. *J. Clin. Endocrinol. Metab.* **88**: 5433–5437.
26. Kobberling, J., B. Willms, R. Kattermann, and W. Creutzfeldt. 1975. Lipodystrophy of the extremities. A dominantly inherited syndrome associated with lipatrophic diabetes. *Humangenetik.* **29**: 111–120.
27. Dunnigan, M. G., M. A. Cochrane, A. Kelly, and J. W. Scott. 1974. Familial lipoatrophic diabetes with dominant transmission. A new syndrome. *Q. J. Med.* **43**: 33–48.
28. Kobberling, J., and M. G. Dunnigan. 1986. Familial partial lipodystrophy: two types of an X linked dominant syndrome, lethal in the hemizygous state. *J. Med. Genet.* **23**: 120–127.
29. Garg, A., R. M. Peshock, and J. L. Fleckenstein. 1999. Adipose tissue distribution pattern in patients with familial partial lipodystrophy (Dunnigan variety). *J. Clin. Endocrinol. Metab.* **84**: 170–174.
30. Garg, A., M. Vinaitheerthan, P. T. Weatherall, and A. M. Bowcock. 2001. Phenotypic heterogeneity in patients with familial partial lipodystrophy (Dunnigan variety) related to the site of missense mutations in lamin A/C gene. *J. Clin. Endocrinol. Metab.* **86**: 59–65.
31. Hegele, R. A. 2005. Lessons from human mutations in PPAR-gamma. *Int. J. Obes. (Lond).* **29** (Suppl. 1): 31–35.
32. Ludtke, A., J. Genschel, G. Brabant, J. Bauditz, M. Taupitz, M. Koch, W. Wermke, H. J. Worman, and H. H. Schmidt. 2005. Hepatic steatosis in Dunnigan-type familial partial lipodystrophy. *Am. J. Gastroenterol.* **100**: 2218–2224.
33. Garg, A. 2000. Gender differences in the prevalence of metabolic complications in familial partial lipodystrophy (Dunnigan variety). *J. Clin. Endocrinol. Metab.* **85**: 1776–1782.
34. Haque, W. A., E. A. Oral, K. Dietz, A. M. Bowcock, A. K. Agarwal, and A. Garg. 2003. Risk factors for diabetes in familial partial lipodystrophy, Dunnigan variety. *Diabetes Care.* **26**: 1350–1355.
35. Cao, H., and R. A. Hegele. 2000. Nuclear lamin A/C R482Q mutation in Canadian kindreds with Dunnigan-type familial partial lipodystrophy. *Hum. Mol. Genet.* **9**: 109–112.
36. Herbst, K. L., L. R. Tannock, S. S. Deeb, J. Q. Purnell, J. D. Brunzell, and A. Chait. 2003. Kobberling type of familial partial lipodystrophy: an underrecognized syndrome. *Diabetes Care.* **26**: 1819–1824.
37. Hegele, R. 2005. LMNA mutation position predicts organ system involvement in laminopathies. *Clin. Genet.* **68**: 31–34.
38. Capell, B. C., and F. S. Collins. 2006. Human laminopathies: nuclei gone genetically awry. *Nat. Rev. Genet.* **7**: 940–952.
39. Young, S. G., M. Meta, S. H. Yang, and L. G. Fong. 2006. Prelamin A farnesylation and progeroid syndromes. *J. Biol. Chem.* **281**: 39741–39745.
40. Fong, L. G., D. Frost, M. Meta, X. Qiao, S. H. Yang, C. Coffinier, and S. G. Young. 2006. A protein farnesyltransferase inhibitor ameliorates disease in a mouse model of progeria. *Science.* **311**: 1621–1623.
41. Lanktree, M., H. Cao, S. Rabkin, A. Hanna, and R. Hegele. 2007. Novel LMNA mutations seen in patients with familial partial lipodystrophy subtype 2 (FPLD2; MIM 151660). *Clin. Genet.* **71**: 183–186.
42. Hegele, R. A., H. Cao, D. M. Liu, G. A. Costain, V. Charlton-Menys, N. W. Rodger, and P. N. Durrington. 2006. Sequencing of the reannotated LMNB2 gene reveals novel mutations in patients with acquired partial lipodystrophy. *Am. J. Hum. Genet.* **79**: 383–389.
43. Agarwal, A. K., and A. Garg. 2002. A novel heterozygous mutation in peroxisome proliferator-activated receptor-gamma gene in a patient with familial partial lipodystrophy. *J. Clin. Endocrinol. Metab.* **87**: 408–411.
44. Agostini, M., E. Schoenmakers, C. Mitchell, I. Szatmari, D. Savage, A. Smith, O. Rajanayagam, R. Semple, J. Luan, L. Bath, et al. 2006. Non-DNA binding, dominant-negative, human PPARgamma mutations cause lipodystrophic insulin resistance. *Cell Metab.* **4**: 303–311.
45. Al-Shali, K., H. Cao, N. Knoers, A. R. Hermus, C. J. Tack, and R. A. Hegele. 2004. A single-base mutation in the peroxisome proliferator-activated receptor gamma4 promoter associated with altered in vitro expression and partial lipodystrophy. *J. Clin. Endocrinol. Metab.* **89**: 5655–5660.
46. Francis, G. A., G. Li, R. Casey, J. Wang, H. Cao, T. Leff, and R. A. Hegele. 2006. Peroxisomal proliferator activated receptor-gamma deficiency in a Canadian kindred with familial partial lipodystrophy type 3 (FPLD3). *BMC Med. Genet.* **7**: 3.
47. Hegele, R. A., H. Cao, C. Frankowski, S. T. Mathews, and T. Leff.



2002. PPAR $\gamma$  F388L, a transactivation-deficient mutant, in familial partial lipodystrophy. *Diabetes*. **51**: 3586–3590.
48. Hegele, R. A., E. Ur, T. P. Ransom, and H. Cao. 2006. A frameshift mutation in peroxisome-proliferator-activated receptor- $\gamma$  in familial partial lipodystrophy subtype 3 (FPLD3; MIM 604367). *Clin. Genet*. **70**: 360–362.
49. Li, G., and T. Leff. 2007. Altered promoter recycling rates contribute to dominant-negative activity of human peroxisome proliferator-activated receptor- $\gamma$  mutations associated with diabetes. *Mol. Endocrinol.* **21**: 857–864.
50. Monajemi, H., L. Zhang, G. Li, E. H. Jeninga, H. Cao, M. Maas, C. B. Brouwer, E. Kalkhoven, E. Stroes, R. A. Hegele, et al. 2007. Familial partial lipodystrophy phenotype resulting from a single-base mutation in DNA binding domain of peroxisome proliferator-activated receptor  $\gamma$ . *J. Clin. Endocrinol. Metab.* **92**: 1606–1612.
51. Savage, D. B., G. D. Tan, C. L. Acerini, S. A. Jebb, M. Agostini, M. Gurnell, R. L. Williams, A. M. Umpleby, E. L. Thomas, J. D. Bell, et al. 2003. Human metabolic syndrome resulting from dominant-negative mutations in the nuclear receptor peroxisome proliferator-activated receptor- $\gamma$ . *Diabetes*. **52**: 910–917.
52. Morel, C. F., M. A. Thomas, H. Cao, C. H. O'Neil, J. G. Pickering, W. D. Foulkes, and R. A. Hegele. 2006. A LMNA splicing mutation in two sisters with severe Dunnigan-type familial partial lipodystrophy type 2. *J. Clin. Endocrinol. Metab.* **91**: 2689–2695.
53. Hegele, R. A., H. Cao, C. M. Anderson, and I. M. Hramiak. 2000. Heterogeneity of nuclear lamin A mutations in Dunnigan-type familial partial lipodystrophy. *J. Clin. Endocrinol. Metab.* **85**: 3431–3435.
54. Hegele, R. A. 2001. Premature atherosclerosis associated with monogenic insulin resistance. *Circulation*. **103**: 2225–2229.
55. Barraquer, L. 1907. Histoire clinique d'un cas d'atrophie du tissu celluloadipeux. *Neurolog. Zentralblatt*. **26**: 1072–1080.
56. Mitchell, S. W. 1885. Singular case of absence of adipose tissue matter in the upper half of the body. *Am. J. Med. Sci.* **90**: 105–106.
57. Simons, A. 1911. Lipodystrophia progressive. *Z. Ges. Neurol. Psychiat.* **5**: 29–38.
58. Misra, A., A. Peethambaram, and A. Garg. 2004. Clinical features and metabolic and autoimmune derangements in acquired partial lipodystrophy: report of 35 cases and review of the literature. *Medicine (Baltimore)*. **83**: 18–34.
59. Hegele, R. A., J. Yuen, and H. Cao. 2001. Single-nucleotide polymorphisms of the nuclear lamina proteome. *J. Hum. Genet.* **46**: 351–354.
60. Frey, B. J., N. Mohammad, Q. D. Morris, W. Zhang, M. D. Robinson, S. Mnaimeh, R. Chang, Q. Pan, E. Sat, J. Rossant, et al. 2005. Genome-wide analysis of mouse transcripts using exon microarrays and factor graphs. *Nat. Genet.* **37**: 991–996.
61. Misra, A., and A. Garg. 2003. Clinical features and metabolic derangements in acquired generalized lipodystrophy: case reports and review of the literature. *Medicine (Baltimore)*. **82**: 129–146.
62. Chen, D., A. Misra, and A. Garg. 2002. Clinical review 153. Lipodystrophy in human immunodeficiency virus-infected patients. *J. Clin. Endocrinol. Metab.* **87**: 4845–4856.
63. Lo, J. C., K. Mulligan, V. W. Tai, H. Algren, and M. Schambelan. 1998. "Buffalo hump" in men with HIV-1 infection. *Lancet*. **351**: 867–870.
64. Miller, K. K., P. A. Daly, D. Sentochnik, J. Doweiko, M. Samore, N. O. Basgoz, and S. K. Grinspoon. 1998. Pseudo-Cushing's syndrome in human immunodeficiency virus-infected patients. *Clin. Infect. Dis.* **27**: 68–72.
65. Roth, V. R., S. Kravcik, and J. B. Angel. 1998. Development of cervical fat pads following therapy with human immunodeficiency virus type 1 protease inhibitors. *Clin. Infect. Dis.* **27**: 65–67.
66. F. R. A. M. Investigators. 2006. Fat distribution in women with HIV infection. *J. Acquir. Immune Defic. Syndr.* **42**: 562–571.
67. Bacchetti, P., B. Gripshover, C. Grunfeld, S. Heymsfield, H. McCreath, D. Osmond, M. Saag, R. Scherzer, M. Shlipak, and P. Tien. 2005. Fat distribution in men with HIV infection. *J. Acquir. Immune Defic. Syndr.* **40**: 121–131.
68. Tien, P. C., S. R. Cole, C. M. Williams, R. Li, J. E. Justman, M. H. Cohen, M. Young, N. Rubin, M. Augenbraun, and C. Grunfeld. 2003. Incidence of lipoatrophy and lipohypertrophy in the Women's Interagency HIV Study. *J. Acquir. Immune Defic. Syndr.* **34**: 461–466.
69. Grinspoon, S. 2005. Androgen deficiency and HIV infection. *Clin. Infect. Dis.* **41**: 1804–1805.
70. Grinspoon, S., and A. Carr. 2005. Cardiovascular risk and body-fat abnormalities in HIV-infected adults. *N. Engl. J. Med.* **352**: 48–62.
71. Ristig, M., H. Drechsler, and W. G. Powderly. 2005. Hepatic steatosis and HIV infection. *AIDS Patient Care STDS*. **19**: 356–365.
72. Johnsen, S., S. E. Dolan, K. V. Fitch, K. M. Killilea, J. L. Shifren, and S. K. Grinspoon. 2005. Absence of polycystic ovary syndrome features in human immunodeficiency virus-infected women despite significant hyperinsulinemia and truncal adiposity. *J. Clin. Endocrinol. Metab.* **90**: 5596–5604.
73. Kosmiski, L., D. Kuritzkes, K. Lichtenstein, and R. Eckel. 2003. Adipocyte-derived hormone levels in HIV lipodystrophy. *Antivir. Ther.* **8**: 9–15.
74. Mynarcik, D. C., T. Combs, M. A. McNurlan, P. E. Scherer, E. Komaroff, and M. C. Gelato. 2002. Adiponectin and leptin levels in HIV-infected subjects with insulin resistance and body fat redistribution. *J. Acquir. Immune Defic. Syndr.* **31**: 514–520.
75. Cutler, D. L., S. Kaufmann, and G. R. Freidenberg. 1991. Insulin-resistant diabetes mellitus and hypermetabolism in mandibuloacral dysplasia: a newly recognized form of partial lipodystrophy. *J. Clin. Endocrinol. Metab.* **73**: 1056–1061.
76. Simha, V., and A. Garg. 2002. Body fat distribution and metabolic derangements in patients with familial partial lipodystrophy associated with mandibuloacral dysplasia. *J. Clin. Endocrinol. Metab.* **87**: 776–785.
77. Novelli, G., A. Muchir, F. Sangiuolo, A. Helbling-Leclerc, M. R. D'Apice, C. Massart, F. Capon, P. Sbraccia, M. Federici, R. Lauro, et al. 2002. Mandibuloacral dysplasia is caused by a mutation in LMNA-encoding lamin A/C. *Am. J. Hum. Genet.* **71**: 426–431.
78. Bergo, M. O., B. Gavino, J. Ross, W. K. Schmidt, C. Hong, L. V. Kendall, A. Mohr, M. Meta, H. Genant, Y. Jiang, et al. 2002. Zmpste24 deficiency in mice causes spontaneous bone fractures, muscle weakness, and a prelamin A processing defect. *Proc. Natl. Acad. Sci. USA*. **99**: 13049–13054.
79. Aarskog, D., L. Ose, H. Pande, and N. Eide. 1983. Autosomal dominant partial lipodystrophy associated with Rieger anomaly, short stature, and insulinopenic diabetes. *Am. J. Med. Genet.* **15**: 29–38.
80. Gorlin, R. J., J. Cervinka, K. Moller, M. Horrobin, and J. Witkop. 1975. Rieger anomaly and growth retardation (the S-H-O-R-T syndrome). *Birth Defects Orig. Artic. Ser.* **11**: 46–48.
81. Sorge, G., M. Ruggieri, A. Polizzi, A. Scuderi, and M. Di Pietro. 1996. SHORT syndrome: a new case with probable autosomal dominant inheritance. *Am. J. Med. Genet.* **61**: 178–181.
82. Hennekam, R. C. 2006. Hutchinson-Gilford progeria syndrome: review of the phenotype. *Am. J. Med. Genet. A*. **140**: 2603–2624.
83. Pollex, R. L., and R. A. Hegele. 2004. Hutchinson-Gilford progeria syndrome. *Clin. Genet.* **66**: 375–381.
84. Navarro, C. L., P. Cau, and N. Levy. 2006. Molecular bases of progeroid syndromes. *Hum. Mol. Genet.* **15 (Spec. 2)**: R151–R161.
85. Hoepffner, H. J., M. Dreyer, U. Reimers, U. Schmidt-Preuss, H. P. Koepf, and H. W. Rudiger. 1989. A new familial syndrome with impaired function of three related peptide growth factors. *Hum. Genet.* **83**: 209–216.
86. Lebel, M. 2001. Werner syndrome: genetic and molecular basis of a premature aging disorder. *Cell. Mol. Life Sci.* **58**: 857–867.
87. Pivnick, E. K., B. Angle, R. A. Kaufman, B. D. Hall, P. Pitukcheewanont, J. H. Hersh, J. L. Fowlkes, L. P. Sanders, J. M. O'Brien, G. S. Carroll, et al. 2000. Neonatal progeroid (Wiedemann-Rautenstrauch) syndrome: report of five new cases and review. *Am. J. Med. Genet.* **90**: 131–140.
88. Al-Attar, S. A., R. L. Pollex, J. F. Robinson, B. A. Miskie, R. Walcarius, B. K. Rutt, and R. A. Hegele. 2006. Semi-automated segmentation and quantification of adipose tissue in calf and thigh by MRI: a preliminary study in patients with monogenic metabolic syndrome. *BMC Med. Imaging*. **6**: 11.
89. Al-Attar, S. A., R. L. Pollex, J. F. Robinson, B. A. Miskie, R. Walcarius, C. H. Little, B. K. Rutt, and R. A. Hegele. 2007. Quantitative and qualitative differences in subcutaneous adipose tissue stores across lipodystrophy types shown by magnetic resonance imaging. *BMC Med. Imaging*. **7**: 3.